

Wellenmutter Locknut

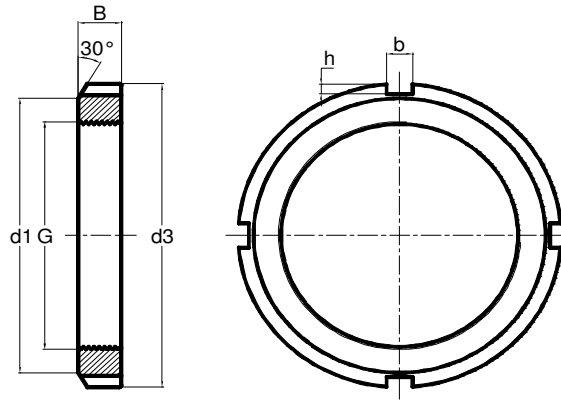

Abmessungen Dimensions						Gewicht Weight	Type Designation	Passendes Sicherungs- blech Locking washer
G	d ₁	d ₃	B	b	h			
mm						kg		
M 10 x 0,75	13,5	18	4	3	2	0,004	KM 0	MB 0
M 12 x 1	17	22	4	3	2	0,007	KM 1	MB 1
M 15 x 1	21	25	5	4	2	0,012	KM 2	MB 2
M 17 x 1	24	28	5	4	2	0,013	KM 3	MB 3
M 20 x 1	26	32	6	4	2	0,02	KM 4	MB 4
M 25 x 1.5	32	38	7	5	2	0,028	KM 5	MB 5
M 30 x 1.5	38	45	7	5	2	0,043	KM 6	MB 6
M 35 x 1.5	44	52	8	5	2	0,053	KM 7	MB 7
M 40 x 1.5	50	58	9	6	2,5	0,085	KM 8	MB 8
M 45 x 1.5	56	65	10	6	2,5	0,12	KM 9	MB 9
M 50 x 1.5	61	70	11	6	2,5	0,15	KM 10	MB 10
M 55 x 2	67	75	11	7	3	0,16	KM 11	MB 11
M 60 x 2	73	80	11	7	3	0,17	KM 12	MB 12
M 65 x 2	79	85	12	7	3	0,2	KM 13	MB 13
M 70 x 2	85	92	12	8	3,5	0,24	KM 14	MB 14
M 75 x 2	90	98	13	8	3,5	0,29	KM 15	MB 15
M 80 x 2	95	105	15	8	3,5	0,4	KM 16	MB 16
M 85 x 2	102	110	16	8	3,5	0,45	KM 17	MB 17
M 90 x 2	108	120	16	10	4	0,56	KM 18	MB 18
M 95 x 2	113	125	17	10	4	0,66	KM 19	MB 19
M 100 x 2	120	130	18	10	4	0,7	KM 20	MB 20
M 105 x 2	126	140	18	12	5	0,85	KM 21	MB 21
M 110 x 2	133	145	19	12	5	0,97	KM 22	MB 22
M 115 x 2	137	150	19	12	5	1,01	KM 23	MB 23

Wellenmutter Locknut

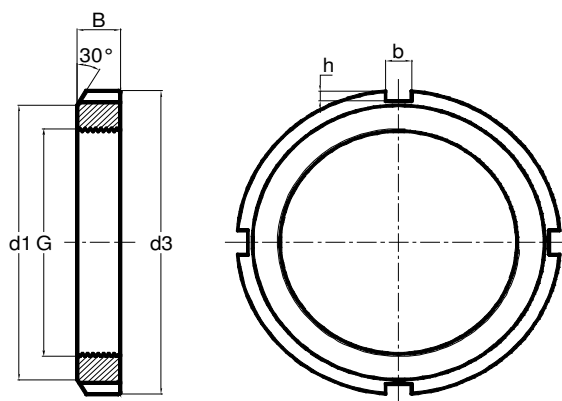

Abmessungen Dimensions						Gewicht Weight	Type Designation	Passendes Sicherungs- blech Locking washer
G	d ₁	d ₃	B	b	h			
mm						kg		
M 120 x 2	135	145	20	12	5	0,78	KML 24	MBL 24
	138	155	20	12	5	1,08	KM 24	MB 24
M 125 x 2	148	160	21	12	5	1,19	KM 25	MB 25
	M 130 x 2	145	155	21	12	5	0,88	KML 26
		149	165	21	12	5	1,25	KM 26
M 135 x 2	160	175	22	14	6	1,55	KM 27	MB 27
M 140 x 2	155	165	22	12	5	0,99	KML 28	MBL 28
		160	180	22	14	6	1,56	KM 28
M 145 x 2	171	190	24	14	6	1,80	KM 29	MB 29
M 150 x 2	170	180	24	14	5	1,38	KML 30	MBL 30
		171	195	24	14	6	2,03	KM 30
M 155 x 3	182	200	25	16	7	2,30	KM 31	MB 31
M 160 x 3	180	190	25	14	5	1,56	KML 32	MBL 32
		182	210	25	16	7	2,59	KM 32
M 165 x 3	193	210	26	16	7	2,70	KM 33	MB 33
M 170 x 3	190	200	26	16	5	1,72	KML 34	MBL 34
		193	220	26	16	7	2,80	KM 34
M 180 x 3	200	210	27	16	5	1,95	KML 36	MBL 36
		203	230	27	18	8	3,07	KM 36
M 190 x 3	210	220	28	16	5	2,08	KML 38	MBL 38
		214	240	28	18	8	3,39	KM 38
M 200 x 3	222	240	29	18	8	2,98	KML 40	MBL 40
		226	250	29	18	8	3,69	KM 40

Wellenmutter Locknut

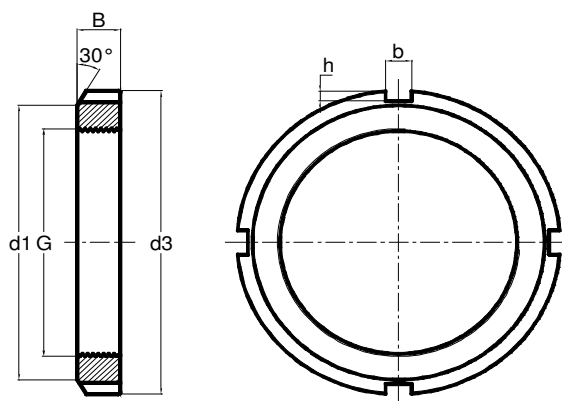

Abmessungen Dimensions						Gewicht Weight	Type Designation	Passendes Sicherungs- blech Locking washer	
G	d ₁	d ₃	B	b	h				
mm						kg			
Tr 205 x 4	232	250	30	18	8	3,43	HML 41 T	-	
Tr 210 x 4	238	270	30	20	10	5,10	HM 42 T	-	
Tr 215 x 4	242	260	30	20	9	3,72	HML 43 T	-	
Tr 220 x 4	250	280	32	20	10	4,75	HM 44 T	MB 44	
Tr 230 x 4	260	290	34	20	10	5,45	HM 46 T		
Tr 235 x 4	262	280	34	20	9	4,29	HML 47 T	-	
Tr 240 x 4	270	300	34	20	10	5,60	HM 48 T	MB 48	
Tr 250 x 4	290	320	36	20	10	7,45	HM 50 T	-	
Tr 260 x 4	290	310	30	20	10	5,15	HML 52 T	-	
		300	330	36	24	12	7,55	HM 52 T	MB 52
Tr 270 x 4	310	340	36	24	12	9,2	HM 54 T	-	
Tr 280 x 4	310	330	30	24	10	5,49	HML 56 T	-	
		320	350	38	24	12	8,65	HM 56 T	MB 56
Tr 290 x 4	335	365	36	24	12	6,8	HM 58 T	-	
Tr 300 x 4	336	360	31	24	12	10,3	HML 60 T	-	
		340	370	36	24	12	6,3	HM 60 T	-
Tr 310 x 5	350	380	36	24	12	7,25	HM 62 T	-	
Tr 320 x 5	356	380	32	24	12	7,97	HML 64 T	-	
		370	400	40	24	12	12	HM 64 T	-
Tr 330 x 5	380	410	40	28	15	13,8	HM 66 T	-	
Tr 340 x 5	390	420	42	28	15	14,6	HM 68 T	-	
Tr 345 x 5	384	410	33	28	13	9,51	HML 69 T	-	
Tr 350 x 5	400	430	42	28	15	15,4	HM 70 T	-	
Tr 360 x 5	394	420	35	28	13	10,2	HML 72 T	-	
		410	440	45	28	15	16,5	HM 72 T	-

Wellenmutter Locknut

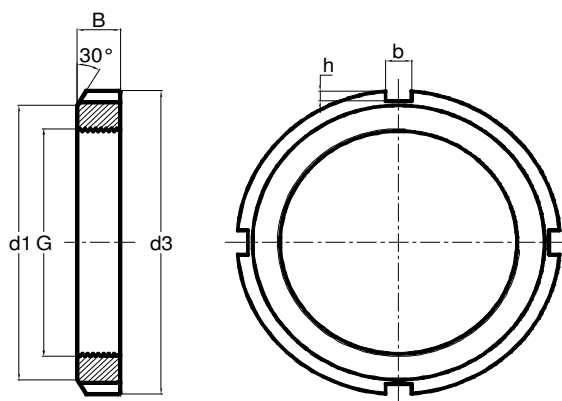

Abmessungen Dimensions						Gewicht Weight	Type Designation	Passendes Sicherungs- blech Locking washer
G	d ₁	d ₃	B	b	h			
mm						kg		
T 365 x 5	404	430	35	28	13	10,7	HML 73 T	-
Tr 370 x 5	420	450	45	28	15	17,4	HM 74 T	-
Tr 380 x 5	417	445	37	28	14	11,3	HML 76 T	-
	430	470	45	30	18	20,2	HM 76 T	-
Tr 385 x 5	422	450	37	28	14	11,8	HML 77 T	-
Tr 400 x 5	460	500	46	32	18	23,8	HM 80 T	-
Tr 410 x 5	452	480	39	32	14	14,3	HML 82 T	-
Tr 420 x 5	480	520	49	32	18	26,6	HM 84 T	-
Tr 430 x 5	472	500	41	32	14	15,8	HML 86 T	-
Tr 440 x 5	500	540	51	36	20	28,8	HM 88 T	-
Tr 450 x 5	490	520	41	32	15	16,3	HML 90 T	-
Tr 460 x 5	510	550	53	36	20	28,8	HM 92 T	-
Tr 470 x 5	510	540	43	32	15	18,3	HML 94 T	-
Tr 480 x 5	590	590	56	56	20	37,5	HM 96 T	-
Tr 490 x 5	540	570	45	36	15	22,5	HML 98 T	-
Tr 510 x 6	570	620	58	40	23	41,2	HM 102 T	-
Tr 520 x 6	570	600	47	36	15	25,3	HMK 104 T	-
Tr 530 x 6	590	640	60	40	23	44,2	HM 106 T	-
Tr 540 x 6	590	620	49	40	20	27	HML 108 T	-
Tr 550 x 6	620	670	63	40	23	53,3	HM 110 T	-
Tr 560 x 6	610	650	60	40	20	32	HML 112 T	-
Tr 580 x 6	645	700	65	40	23	57,3	HM 116 T	-
Tr 590 x 6	650	690	63	40	20	47,7	HML 118 T	-
Tr 610 x 6	674	730	65	45	25	59,7	HM 122 T	-
Tr 630 x 6	690	730	65	45	20	52,2	HML 126 T	-

Wellenmutter Locknut

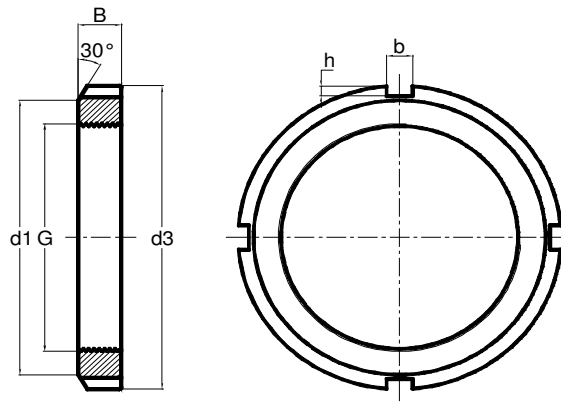

Abmessungen Dimensions						Gewicht Weight	Type Designation	Passendes Sicherungs- blech Locking washer
G	d ₁	d ₃	B	b	h			
mm						kg		
Tr 650 x 6	720	780	67	45	25	70,9	HM 130 T	-
Tr 670 x 6	730	770	70	45	20	59,8	HML 134 T	-
Tr 680 x 6	750	820	72	50	28	84,8	HM 136 T	-
Tr 710 x 7	780	830	70	50	25	75,7	HML 142 T	-
Tr 720 x 7	800	870	72	50	28	97,8	HM 144 T	-
Tr 750 x 7	820	870	70	55	25	79,6	HML 150 T	-
Tr 760 x 7	830	910	750	55	30	104	HM 152 T	-
Tr 800 x 7	865	920	70	55	25	84	HML 160 T	-
	870	950	75	60	34	109	HM 160 T	-
Tr 850 x 7	915	970	74	60	25	94	HML 170 T	-
	930	1010	79	60	34	131	HM 170 T	-