

SPANNHÜLSEN

ADAPTER SLEEVES

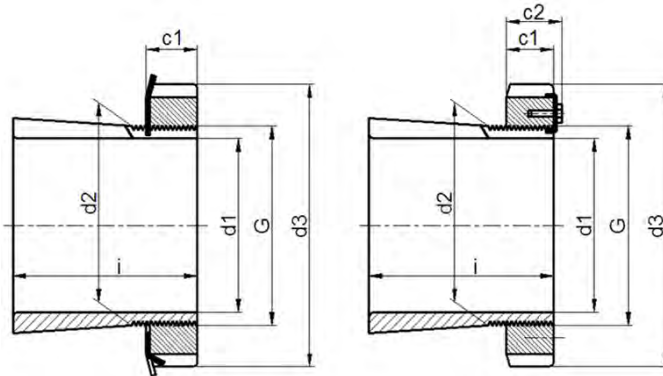

H+MB / MBL

H+MS

Welle Shaft	Abmessungen Dimensions						Gewicht Weight	Hülse komplett mit Sleeve mounted with		Bezeichnung Designation
	d1	d2	l	d3	G	c1		c2	Mutter Locknut	
mm							kg			
17	20	24	32	M 20x1	7	-	0,041	KM 4	MB 4	H 204
	20	28	32	M 20x1	7	-	0,045	KM 4	MB 4	H 304
	20	31	32	M 20x1	7	-	0,049	KM 4	MB 4	H 2304
20	25	26	38	M 25x1,5	8	-	0,07	KM 5	MB 5	H 205
	25	29	38	M 25x1,5	8	-	0,075	KM 5	MB 5	H 305
	25	35	38	M 25x1,5	8	-	0,087	KM 5	MB 5	H 2305
25	30	27	45	M 30x1,5	8	-	0,099	KM 6	MB 6	H 206
	30	31	45	M 30x1,5	8	-	0,109	KM 6	MB 6	H 306
	30	38	45	M 30x1,5	8	-	0,126	KM 6	MB 6	H 2306
30	35	29	52	M 35x1,5	9	-	0,125	KM 7	MB 7	H 207
	35	35	52	M 35x1,5	9	-	0,142	KM 7	MB 7	H 307
	35	43	52	M 35x1,5	9	-	0,165	KM 7	MB 7	H 2307
35	40	31	58	M 40x1,5	10	-	0,174	KM 8	MB 8	H 208
	40	36	58	M 40x1,5	10	-	0,189	KM 8	MB 8	H 308
	40	46	58	M 40x1,5	10	-	0,224	KM 8	MB 8	H 2308
40	45	33	65	M 45x1,5	11	-	0,227	KM 9	MB 9	H 209
	45	39	65	M 45x1,5	11	-	0,248	KM 9	MB 9	H 309
	45	50	65	M 45x1,5	11	-	0,28	KM 9	MB 9	H 2309
45	50	35	70	M 50x1,5	12	-	0,274	KM 10	MB 10	H 210
	50	42	70	M 50x1,5	12	-	0,303	KM 10	MB 10	H 310
	50	55	70	M 50x1,5	12	-	0,362	KM 10	MB 10	H 2310
50	55	37	75	M 55x2	12,5	-	0,308	KM 11	MB 11	H 211
	55	45	75	M 55x2	12,5	-	0,345	KM 11	MB 11	H 311
	55	59	75	M 55x2	12,5	-	0,42	KM 11	MB 11	H 2311
55	60	38	80	M 60x2	13	-	0,346	KM 12	MB 12	H 212
	60	47	80	M 60x2	13	-	0,394	KM 12	MB 12	H 312
	60	62	80	M 60x2	13	-	0,481	KM 12	MB 12	H 2312
60	65	40	85	M 65x2	14	-	0,401	KM 13	MB 13	H 213
	65	50	85	M 65x2	14	-	0,458	KM 13	MB 13	H 313
	65	65	85	M 65x2	14	-	0,557	KM 13	MB 13	H 2313
	70	41	92	M 70x2	14	-	0,593	KM 14	MB 14	H 214
	70	52	92	M 70x2	14	-	0,723	KM 14	MB 14	H 314
	70	68	92	M 70x2	14	-	0,897	KM 14	MB 14	H 2314

SPANNHÜLSEN

ADAPTER SLEEVES

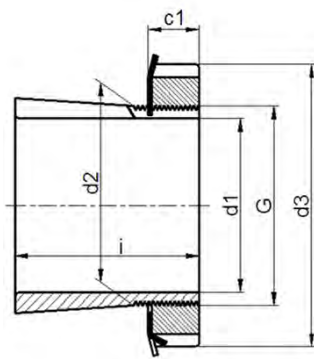

H+MB / MBL

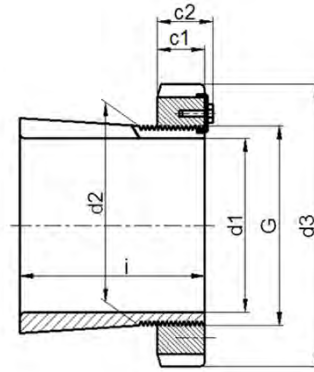

H+MS

Welle Shaft	Abmessungen Dimensions						Gewicht Weight	Hülse komplett mit Sleeve mounted with		Bezeichnung Designation
	d1	d2	l	d3	G	c1		c2	Mutter Locknut	
mm							kg			
65	75	43	98	M 75x2	15	-	0,707	KM 15	MB 15	H 215
	75	55	98	M 75x2	15	-	0,831	KM 15	MB 15	H 315
	75	73	98	M 75x2	15	-	1,05	KM 15	MB 15	H 2315
70	80	46	105	M 80x2	17	-	0,882	KM 16	MB 16	H 216
	80	59	105	M 80x2	17	-	1,03	KM 16	MB 16	H 316
	80	78	105	M 80x2	17	-	1,28	KM 16	MB 16	H 2316
75	85	50	110	M 85x2	18	-	1,02	KM 17	MB 17	H 217
	85	63	110	M 85x2	18	-	1,18	KM 17	MB 17	H 317
	85	82	110	M 85x2	18	-	1,45	KM 17	MB 17	H 2317
80	90	52	120	M 90x2	18	-	1,19	KM 18	MB 18	H 218
	90	65	120	M 90x2	18	-	1,37	KM 18	MB 18	H 318
	90	86	120	M 90x2	18	-	1,69	KM 18	MB 18	H 2318
85	95	55	125	M 95x2	19	-	1,37	KM 19	MB 19	H 219
	95	68	125	M 95x2	19	-	1,56	KM 19	MB 19	H 319
	95	90	125	M 95x2	19	-	1,92	KM 19	MB 19	H 2319
90	100	58	130	M 100x2	20	-	1,49	KM 20	MB 20	H 220
	100	71	130	M 100x2	20	-	1,69	KM 20	MB 20	H 320
	100	76	130	M 100x2	20	-	1,80	KM 20	MB 20	H 3120
	100	97	130	M 100x2	20	-	2,15	KM 20	MB 20	H 2320
95	105	60	140	M 105x2	20	-	1,72	KM 21	MB 21	H 221
	105	74	140	M 105x2	20	-	1,95	KM 21	MB 21	H 321
100	110	63	145	M 110x2	21	-	1,93	KM 22	MB 22	H 222
	110	77	145	M 110x2	21	-	2,18	KM 22	MB 22	H 322
	110	81	145	M 110x2	21	-	2,25	KM 22	MB 22	H 3122
	110	105	145	M 110x2	21	-	2,74	KM 22	MB 22	H 2322
110	120	72	145	M 120x2	22	-	1,93	KML 24	MBL 24	H 3024
	120	88	155	M 120x2	22	-	2,64	KM 24	MB 24	H 3124
	120	112	155	M 120x2	22	-	3,19	KM 24	MB 24	H 2324
115	130	80	155	M 130x2	23	-	2,85	KML 26	MBL 26	H 3026
	130	92	165	M 130x2	23	-	3,66	KM 26	MB 26	H 3126
	130	121	165	M 130x2	23	-	4,60	KM 26	MB 26	H 2326

SPANNHÜLSEN

ADAPTER SLEEVES

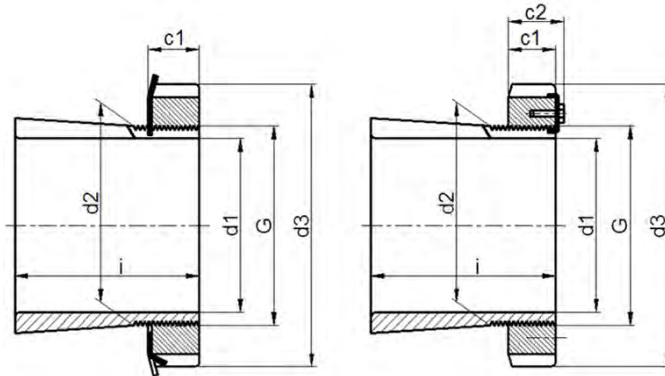

H+MB / MBL

H+MS

Welle Shaft	Abmessungen Dimensions						Gewicht Weight	Hülse komplett mit Sleeve mounted with		Bezeichnung Designation
	d1	d2	l	d3	G	c1		c2	Mutter Locknut	
mm							kg			
125	140	82	165	M 140x2	24	-	3,16	KML 28	MBL 28	H 3028
	140	97	180	M 140x2	24	-	4,34	KM 28	MB 28	H 3128
	140	131	180	M 140x2	24	-	5,55	KM 28	MB 28	H 2328
135	150	87	180	M 150x2	26	-	3,89	KML 30	MBL 30	H 3030
	150	111	195	M 150x2	26	-	5,52	KM 30	MB 30	H 3130
	150	139	195	M 150x2	26	-	6,63	KM 30	MB 30	H 2330
140	160	93	190	M 160x3	27,5	-	5,21	KML 32	MBL 32	H 3032
	160	119	210	M 160x3	28	-	7,67	KM 32	MB 32	H 3132
	160	147	210	M 160x3	28	-	9,14	KM 32	MB 32	H 2332
150	170	101	200	M 170x3	28,5	-	5,21	KML 32	MBL 32	H 3032
	170	122	220	M 170x3	29	-	7,67	KM 32	MB 32	H 3132
	170	154	220	M 170x3	29	-	9,14	KM 32	MB 32	H 2332
160	180	87	210	M 180x3	29,5	-	5,70	KML 36	MBL 36	H 3936
	180	109	210	M 180x3	29,5	-	6,83	KML 36	MBL 36	H 3036
	180	131	230	M 180x3	30	-	9,50	KM 36	MB 36	H 3136
	180	161	230	M 180x3	30	-	11,30	KM 36	MB 36	H 2336
170	190	89	220	M 190x3	30,5	-	6,19	KML 38	MBL 38	H 3938
	190	112	220	M 190x3	30,5	-	7,45	KML 38	MBL 38	H 3038
	190	141	240	M 190x3	31	-	10,80	KM 38	MB 38	H 3138
	190	169	240	M 190x3	31	-	12,60	KM 38	MB 38	H 2338
180	200	98	240	M 200x3	31,5	-	7,89	KML 40	MBL 40	H 3940
	200	120	240	M 200x3	31,5	-	9,19	KML 40	MBL 40	H 3040
	200	150	250	M 200x3	32	-	12,10	KM 40	MB 40	H 3140
	200	176	250	M 200x3	32	-	12,40	KM 40	MB 40	H 2340
200	220	96	260	Tr 220x4	30	41	8,16	HM 3044	MS 3044	H 3944
	220	126	260	Tr 220x4	30	41	10,30	HM 3044	MS 3044	H 3044
	220	161	280	Tr 220x4	35	-	15,00	HM 44 T	MB 44	H 3144
	220	186	280	Tr 220x4	35	-	17,00	HM 44 T	MB 44	H 2344
220	240	101	290	Tr 240x4	34	46	11,00	HM 3048	MS 3048	H 3948
	240	133	290	Tr 240x4	34	46	13,20	HM 3048	MS 3048	H 3048

SPANNHÜLSEN

ADAPTER SLEEVES

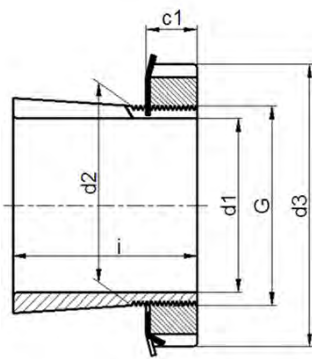

H+MB / MBL

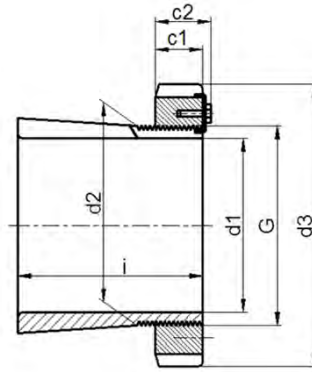

H+MS

Welle Shaft	Abmessungen Dimensions						Gewicht Weight	Hülse komplett mit Sleeve mounted with		Bezeichnung Designation
	d1	d2	l	d3	G	c1		c2	Mutter Locknut	
mm							kg			
220	240	172	300	Tr 240x4	37	-	17,60	HM 48 T	MB 48	H 3148
	240	199	300	Tr 240x4	37	-	20,00	HM 48 T	MB 48	H 2348
240	260	116	310	Tr 260x4	34	46	12,80	HM 3052	MS 3052	H 3952
	260	145	310	Tr 260x4	34	46	15,30	HM 3052	MS 3052	H 3052
	260	190	330	Tr 260x4	39	-	22,30	HM 52 T	MB 52	H 3152
	260	211	330	Tr 260x4	39	-	24,50	HM 52 T	MB 52	H 2352
260	280	121	330	Tr 280x4	38	50	15,30	HM 3056	MS 3056	H 3956
	280	152	330	Tr 280x4	38	50	17,70	HM 3056	MS 3056	H 3056
	280	195	350	Tr 280x4	41	-	25,10	HM 56 T	MB 56	H 3156
	280	224	350	Tr 280x4	41	-	28,40	HM 56 T	MB 56	H 2356
280	300	140	360	Tr 300x4	42	54	20,00	HM 3060	MS 3060	H 3960
	300	168	360	Tr 300x4	42	54	22,80	HM 3060	MS 3060	H 3060
	300	208	380	Tr 300x4	40	53	30,20	HM 3160	MS 3160	H 3160
	300	240	380	Tr 300x4	40	53	34,10	HM 3160	MS 3160	H 3260
300	320	140	380	Tr 320x5	42	55	21,50	HM 3064	MS 3064	H 3964
	320	171	380	Tr 320x5	42	55	24,60	HM 3064	MS 3064	H 3064
	320	226	400	Tr 320x5	42	56	34,90	HM 3164	MS 3164	H 3164
	320	258	400	Tr 320x5	42	56	39,30	HM 3164	MS 3164	H 3264
320	340	144	400	Tr 340x5	45	58	24,50	HM 3068	MS 3068	H 3968
	340	187	400	Tr 340x5	45	58	28,70	HM 3068	MS 3068	H 3068
	340	254	440	Tr 340x5	55	72	50,00	HM 3168	MS 3168	H 3168
	340	288	440	Tr 340x5	55	72	54,60	HM 3168	MS 3168	H 3268
340	360	144	420	Tr 360x5	45	58	25,20	HM 3072	MS 3072	H 3972
	360	188	420	Tr 360x5	45	58	30,50	HM 3072	MS 3072	H 3072
	360	259	460	Tr 360x5	58	75	56,00	HM 3172	MS 3172	H 3172
	360	299	460	Tr 360x5	58	75	60,60	HM 3172	MS 3172	H 3272
360	380	164	450	Tr 380x5	48	62	31,5	HM 3076	MS 3076	H 3976
	380	193	450	Tr 380x5	48	62	35,8	HM 3076	MS 3076	H 3076
	380	264	490	Tr 380x5	60	77	61,7	HM 3176	MS 3176	H 3176
	380	310	490	Tr 380x5	60	77	69,6	HM 3176	MS 3176	H 3276

SPANNHÜLSEN

ADAPTER SLEEVES

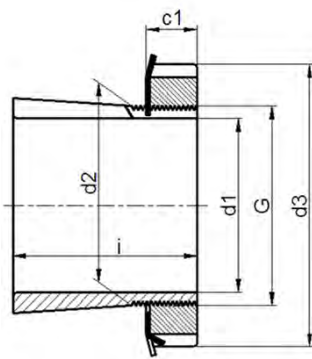

H+MB / MBL

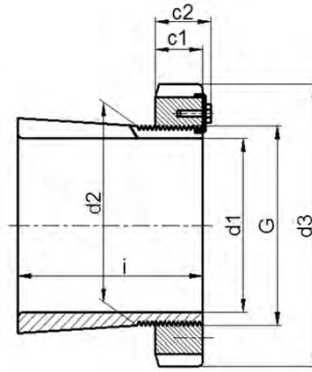

H+MS

Welle Shaft	Abmessungen Dimensions						Gewicht Weight	Hülse komplett mit Sleeve mounted with		Bezeichnung Designation
	d1	d2	l	d3	G	c1		c2	Mutter Locknut	
mm							kg			
380	400	168	470	Tr 400x5	52	66	35,00	HM 3080	MS 3080	H 3980
	400	210	470	Tr 400x5	52	66	41,30	HM 3080	MS 3080	H 3080
	400	272	520	Tr 400x5	62	82	73,00	HM 3180	MS 3180	H 3180
	400	328	520	Tr 400x5	62	82	81,00	HM 3180	MS 3180	H 3280
400	420	168	490	Tr 420x5	52	66	36,60	HM 3084	MS 3084	H 3984
	420	212	490	Tr 420x5	52	66	43,70	HM 3084	MS 3084	H 3084
	420	304	540	Tr 420x5	70	90	84,20	HM 3184	MS 3184	H 3184
	420	352	540	Tr 420x5	70	90	96,00	HM 3184	MS 3184	H 3284
410	440	189	520	Tr 440x5	60	77	58,00	HM 3088	MS 3088	H 3988
	440	228	520	Tr 440x5	60	77	65,20	HM 3088	MS 3088	H 3088
	440	307	560	Tr 440x5	70	90	104,00	HM 3188	MS 3188	H 3188
	440	361	560	Tr 440x5	70	90	118,00	HM 3188	MS 3188	H 3288
430	460	189	540	Tr 460x5	60	77	60,00	HM 3092	MS 3092	H 3992
	460	234	540	Tr 460x5	60	77	71,00	HM 3092	MS 3092	H 3092
	460	326	580	Tr 460x5	75	95	116,00	HM 3192	MS 3192	H 3192
	460	382	580	Tr 460x5	75	95	134,00	HM 3192	MS 3192	H 3292
450	480	200	560	Tr 480x5	60	77	66,00	HM 3096	MS 3096	H 3996
	480	237	560	Tr 480x5	60	77	75,00	HM 3096	MS 3096	H 3096
	480	335	620	Tr 480x5	75	95	135,00	HM 3196	MS 3196	H 3196
	480	397	620	Tr 480x5	75	95	153,00	HM 3196	MS 3196	H 3296
470	500	208	580	Tr 500x5	68	85	74,30	HM 30/500	MS 30/500	H 39/500
	500	247	580	Tr 500x5	68	85	82,00	HM 30/500	MS 30/500	H 30/500
	500	356	630	Tr 500x5	80	100	145,00	HM 31/500	MS 31/500	H 31/500
	500	428	630	Tr 500x5	80	100	166,00	HM 31/500	MS 31/500	H 32/500
500	530	216	630	Tr 530x6	68	90	87,90	HM 30/530	MS 30/530	H 39/530
	530	265	630	Tr 530x6	68	90	105,00	HM 30/530	MS 30/530	H 30/530
	530	364	670	Tr 530x6	80	105	161,00	HM 31/530	MS 31/530	H 31/530
	530	447	670	Tr 530x6	80	105	192,00	HM 31/530	MS 31/530	H 32/530

SPANNHÜLSEN

ADAPTER SLEEVES

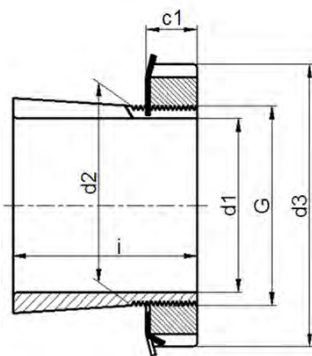

H+MB / MBL

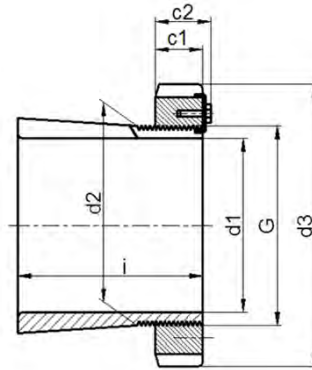

H+MS

Welle Shaft	Abmessungen Dimensions						Gewicht Weight	Hülse komplett mit Sleeve mounted with		Bezeichnung Designation
	d1	d2	l	d3	G	c1		c2	Mutter Locknut	
mm							kg			
530	560	227	650	Tr 560x6	75	97	95,00	HM 30/560	MS 30/560	H 39/560
	560	282	650	Tr 560x6	75	97	112,00	HM 30/560	MS 30/560	H 30/560
	560	377	710	Tr 560x6	85	110	185,00	HM 31/560	MS 31/560	H 31/560
	560	462	710	Tr 560x6	85	110	219,00	HM 31/560	MS 31/560	H 32/560
560	600	239	700	Tr 600x6	75	97	127,00	HM 30/600	MS 30/600	H 39/600
	600	289	700	Tr 600x6	75	97	147,00	HM 30/600	MS 30/600	H 30/600
	600	399	750	Tr 600x6	85	110	234,00	HM 31/600	MS 31/600	H 31/600
	600	487	750	Tr 600x6	85	110	278,00	HM 31/600	MS 31/600	H 32/600
600	630	254	730	Tr 630x6	75	97	120,00	HM 30/630	MS 30/630	H 39/630
	630	301	730	Tr 630x6	75	97	138,00	HM 30/630	MS 30/630	H 30/630
	630	424	800	Tr 630x6	95	120	254,00	HM 31/630	MS 31/630	H 31/630
	630	521	800	Tr 630x6	95	120	300,00	HM 31/630	MS 31/630	H 32/630
630	670	264	780	Tr 670x6	80	102	163,00	HM 30/670	MS 30/670	H 39/670
	670	324	780	Tr 670x6	80	102	191,00	HM 30/670	MS 30/670	H 30/670
	670	456	850	Tr 670x6	106	131	340,00	HM 31/670	MS 31/670	H 31/670
	670	558	850	Tr 670x6	106	131	401,00	HM 31/670	MS 31/670	H 32/670
670	710	286	830	Tr 710x7	90	112	196,00	HM 30/710	MS 30/710	H 39/710
	710	342	830	Tr 710x7	90	112	223,00	HM 30/710	MS 30/710	H 30/710
	710	467	900	Tr 710x7	106	135	378,00	HM 31/710	MS 31/710	H 31/710
	710	572	900	Tr 710x7	106	135	444,00	HM 31/710	MS 31/710	H 32/710
710	750	291	870	Tr 750x7	90	112	211,00	HM 30/750	MS 30/750	H 39/750
	750	356	870	Tr 750x7	90	112	246,00	HM 30/750	MS 30/750	H 30/750
	750	493	950	Tr 750x7	112	141	451,00	HM 31/750	MS 31/750	H 31/750
	750	603	950	Tr 750x7	112	141	507,00	HM 31/750	MS 31/750	H 32/750
750	800	303	920	Tr 800x7	90	112	259,00	HM 30/800	MS 30/800	H 39/800
	800	366	920	Tr 800x7	90	112	300,00	HM 30/800	MS 30/800	H 30/800
	800	505	1000	Tr 800x7	112	141	515,00	HM 31/800	MS 31/800	H 31/800
	800	618	1000	Tr 800x7	112	141	610,00	HM 31/800	MS 31/800	H 32/800

SPANNHÜLSEN

ADAPTER SLEEVES

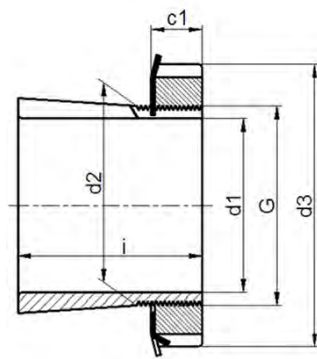

H+MB / MBL

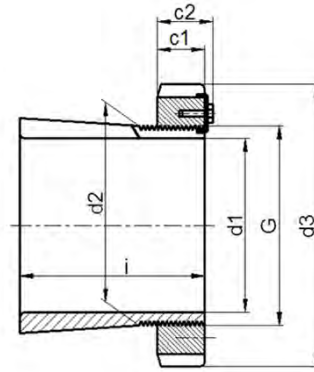

H+MS

Welle Shaft	Abmessungen Dimensions						Gewicht Weight	Hülse komplett mit Sleeve mounted with		Bezeichnung Designation	
d1	d2	l	d3	G	c1	c2		Mutter Locknut	Sicherung Locking Device	Hülse Sleeve	
	mm						kg				

Auf Anfrage sind folgende Ausführungen lieferbar:

